

# Oilgear

MFV & MVW Fixed & Variable  
Displacement Bi-Directional Motors

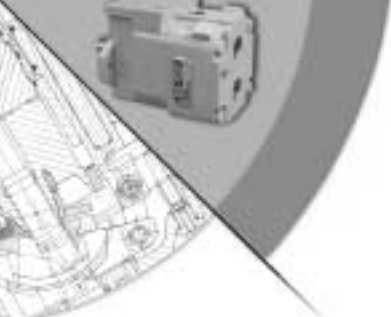



# Table of Contents

Performance Assurance	page <b>3</b>
Features and Benefits	<b>4</b>
Specifications	<b>5</b>
Fixed Displacement Motors	<b>5</b>
Variable Displacement Motors	<b>6</b>
Dimensions & Weights	<b>7</b>
Controls	
Fixed Displacement	<b>8</b>
Variable Displacement/Mechanical	<b>8</b>
Variable Displacement/Solenoid	<b>9</b>
Variable Displacement/Hydraulic	<b>9</b>
Performance Curves	
Torque vs Net Pressure	<b>10</b>
Horsepower vs Speed	<b>11</b>
Overall Efficiency vs Net Pressure	<b>12-13</b>
Ordering Information	<b>14</b>

## PERFORMANCE ASSURANCE – STANDARD WITH EVERY OILGEAR COMPONENT



**Every** Oilgear product is shipped to you with our Performance Assurance — a corporate commitment to stay with your installation until our equipment performs as specified.

Hydraulic equipment and systems have been Oilgear's primary business since 1921. For decades, we have developed hydraulic techniques to meet the unique needs and unusual fluid power problems of machinery builders and users worldwide, matching fluid power systems to a tremendous range of applications and industries. Our exclusive Performance Assurance program is built upon that strong foundation.

As a customer, you also benefit from access to Oilgear's impressive technical support network. You'll find factory trained and field-experienced application engineers on staff at every Oilgear facility. They are backed by headquarters staff who can access the records and knowledge learned from decades of solving the most difficult hydraulic challenges.

When your design or purchase is complete, our service is just beginning. If you ever need us, our Oilgear engineers will be there, ready to help you with the education, field service, parts and repairs to assure that your installation runs smoothly — and keeps right on running.

**Oilgear** Performance Assurance

# Bi-Directional Motors

Cylinder mounted in polymerous journal bearing

- Allows operation with special fluids
- Provides infinite bearing life
- Allows compact design

Totally enclosed (no openings to atmosphere)

- Can be operated in demanding locations
- Sealed against even high pressure wash downs

Cartridge construction

- Simplifies field servicing
- Expedites replacement parts ordering and stocking

SAE keyed or SAE splined shaft

- Heavy-duty belt shafts also available

Hardened cylinder surface running on hardened valve plate ("hard on hard")

- Provides greater resistance to contaminants
- Allows operation with special fluid
- Provides longer life

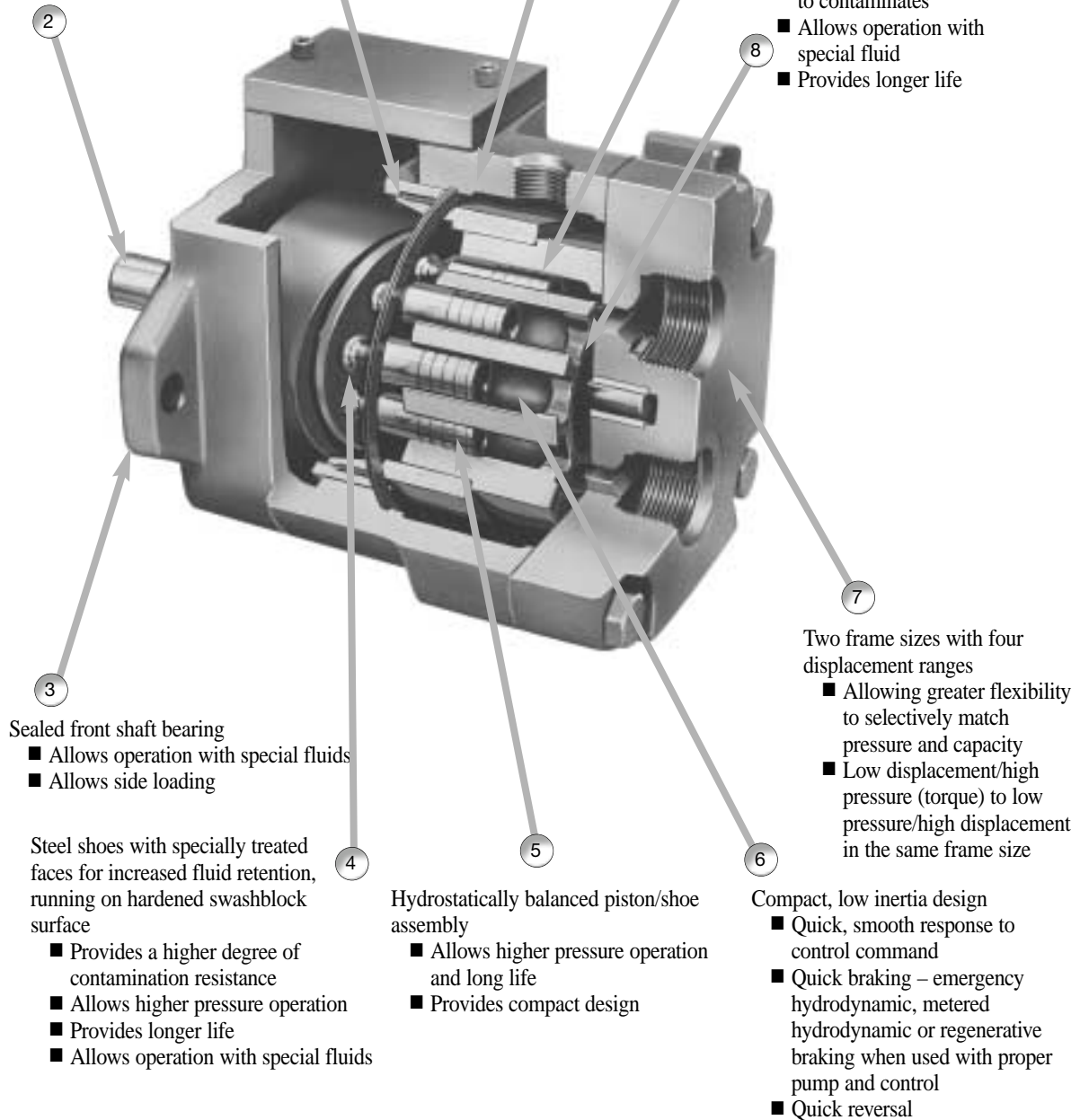

Sealed front shaft bearing

- Allows operation with special fluids
- Allows side loading

Steel shoes with specially treated faces for increased fluid retention, running on hardened swashblock surface

- Provides a higher degree of contamination resistance
- Allows higher pressure operation
- Provides longer life
- Allows operation with special fluids

Hydrostatically balanced piston/shoe assembly

- Allows higher pressure operation and long life
- Provides compact design

Two frame sizes with four displacement ranges

- Allowing greater flexibility to selectively match pressure and capacity
- Low displacement/high pressure (torque) to low pressure/high displacement in the same frame size

Compact, low inertia design

- Quick, smooth response to control command
- Quick braking – emergency hydrodynamic, metered hydrodynamic or regenerative braking when used with proper pump and control
- Quick reversal

# SPECIFICATIONS

## Nominal Performance Data with 150-300 SSU viscosity fluids

FRAME SIZE	UNIT SIZE	THEORETICAL MAXIMUM DISPLACEMENT		RATED CONTINUOUS PRESSURE		MAXIMUM PRESSURE		PRESSURE Break-away		SPEED		TORQUE at contin. pres. displ.		OUTPUT at 1800 rpm, cont. pres. max. displ.		INERTIA	
		cipr	mlpr	psi	bar	psi	bar	psi	bar	rpm	rpm	lb.in.	N.m.	hp	kw	lbs. ft <sup>2</sup>	kgm <sup>2</sup>
A	06	0.86	14,1	4000	276	4500	310	500	34,5	600	3000	465	52,5	13,3	9,9	0.029	0,0012
	10	1.35	22,1	3000	207	3500	242	500	34,5	600	3000	562	63,5	16,1	11,9	0.029	0,0012
B	15	2.06	33,8	3500	242	4000	276	330	22,8	600	3000	1030	116,4	30,0	22,4	0.130	0,0055
	20	2.83	46,4	2500	173	3000	207	330	22,8	600	3000	960	108,5	27,5	20,5	0.130	0,0055

## FIXED DISPLACEMENT MOTORS

### = Bi-Directional Constant Torque/Variable Horsepower

Motor torque is a function of pressure and motor displacement. Pressure is generated by the load, but limited by the pump relief valve or operation of pump control. Motor displacement (in this case) is fixed. So maximum motor torque is available whether motor is stalled or going full rpm.

Horsepower output, with a constant working torque (pressure) is approximately proportional to speed – which is regulated by pump volume delivered to the motor. Thus, it is possible to reduce pump delivery, when stalled, or bring motor and load up to speed, while maintaining full torque and without wasting horsepower.



## VARIABLE DISPLACEMENT MOTORS

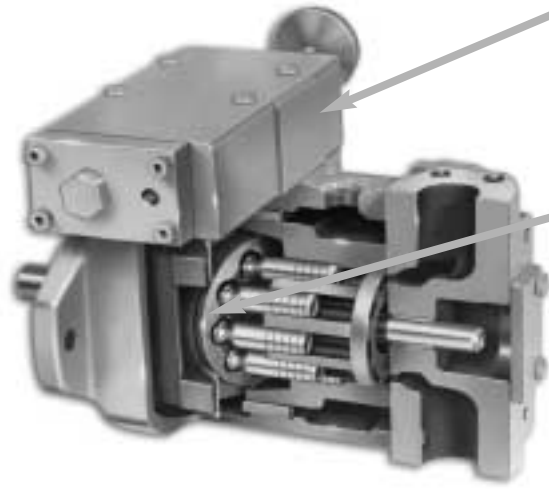

Control selection available

- Four different types of controls – including manual, solenoid, and hydraulic
- Field interchangeability without disconnecting motor from driven component or system piping

Patented pressure lubricated swashblock design

- Provides high performance operation

### = Constant Horsepower/Variable Torque

Speed of these variable displacement motors, when driven by a fixed delivery hydrostatic pump, can be adjusted over a 4:1 range. But, each motor has a maximum rated speed (see “Specifications”) that must not be exceeded when motor displacement is varied. With a fixed volume delivery to the motor, reducing motor displacement increases output speed and reduces available torque. These constant horsepower/variable torque drives are limited to uni-directional applications unless a reversing valve is incorporated in the high pressure circuit.

### = Constant Torque or Constant Horsepower

A variable displacement motor driven by a variable delivery pump provides either constant torque or constant horsepower at variable (and reversible) speed. Maximum torque is available when motor is at full displacement. Speed and direction of rotation respond to pump control.

Speed can be increased (to shaft speed limit), when pump is at full volume, by reducing motor displacement. Horsepower output will remain constant, over this higher operating range, while torque will vary inversely with speed (motor displacement). This system provides constant torque (and variable power) until pump reaches full delivery and constant power (and variable torque) as motor displacement is reduced and output speed increased.



# DIMENSIONS & WEIGHTS

FRAME SIZE	MOTOR SIZE	HEIGHT		WIDTH		LENGTH		WEIGHT	
		in.	mm.	in.	mm.	in.	mm.	lbs.	kg
A	6 & 10	5.75	131	5.12	130	7.29	227	32	14.5
B	15 & 20	7.06	172	6.88	175	8.54	274	68	31

All dimensions are approximate. For detailed dimensions, see Data Sheet 47882 ("A" Frame) or 47883 ("B" Frame).

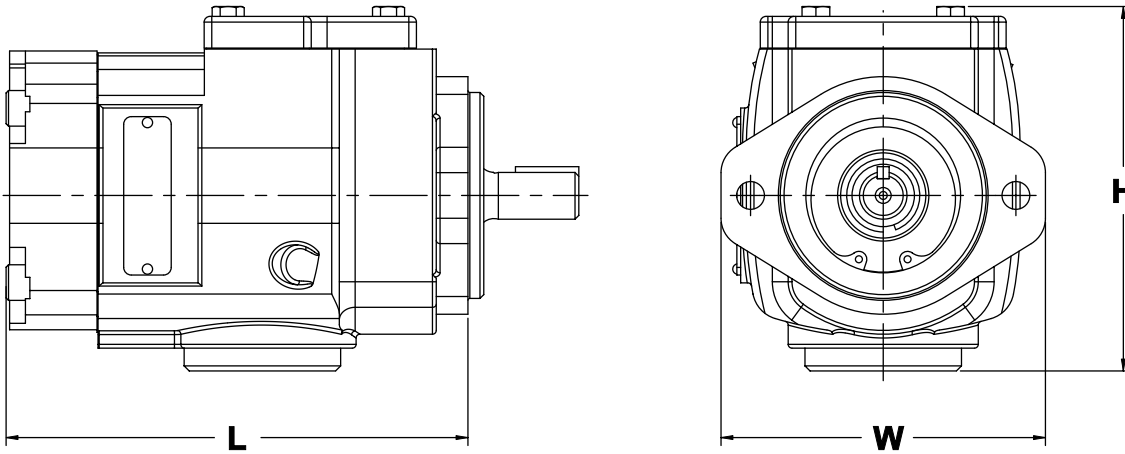

MVW Dimensions & Weights Reference Data

MW	SIZE	REFERENCE
HN Control	06 & 10	Data Sheet 47170
	15 & 20	Data Sheet 47171
MN Control	06 & 10	Data Sheet 47175
	15 & 20	Data Sheet 47176
HD Control	06 & 10	Data Sheet 47880
	15 & 20	Data Sheet 47881
RU Control	06 & 10	Data Sheet 47871
	15 & 20	Data Sheet 47872

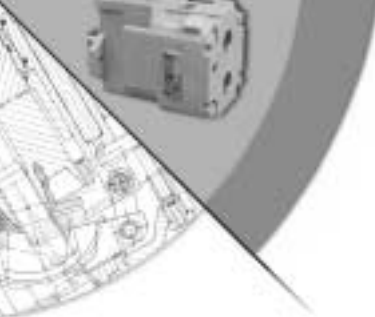

# Motor Controls\*

## FIXED DISPLACEMENT

■ No Control

“NN”

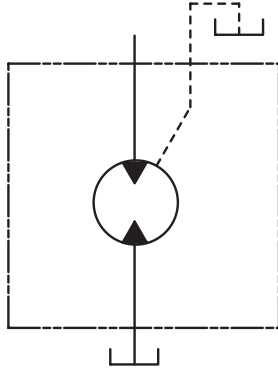

## VARIABLE DISPLACEMENT CONTROLS\*\*

### MECHANICAL

■ Handwheel

“HN”

Provides a simple manual adjustment of displacement.

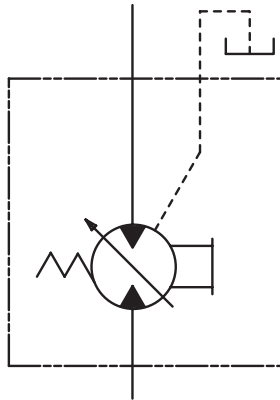

■ Lever

“MN”

Can rotate a pintle and vary displacement proportionally.

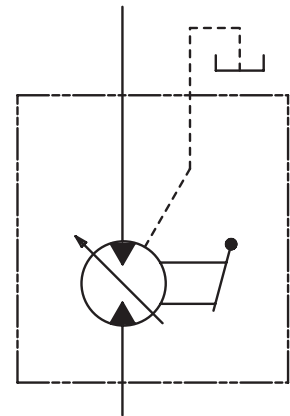

\* Be sure system and motors are protected against overloads with a high pressure relief valve.

\*\* Be sure minimum displacement is set (displacement stop) to prevent output rpm from exceeding maximum rated speed.



## SOLENOID

### ■ Two Displacements

**“RU”**

Two adjustable displacements selected by operation of valve.

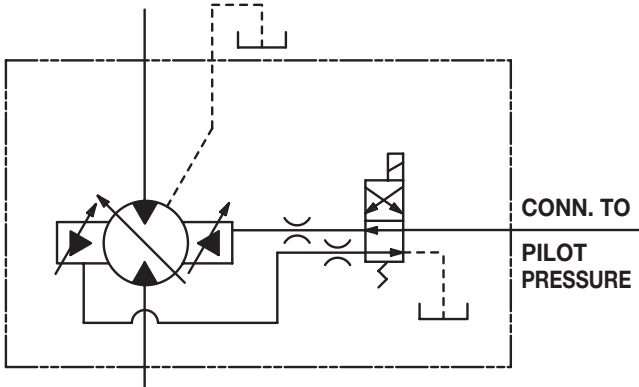

## HYDRAULIC

### ■ De-stroker

**“HD”**

Two displacements, full stroke and adjustable reduced stroke activated by user-supplied pilot pressure.

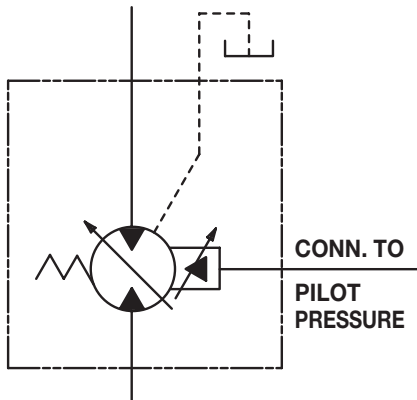

**Oilgear** Motor Controls\*

\* Be sure system and motors are protected against overloads with a high pressure relief valve.

\*\* Be sure minimum displacement is set (displacement stop) to prevent output rpm from exceeding maximum rated speed.

# PERFORMANCE

All curves are based on typical units operating with 140 SSU fluid at 125°F and 75 psi back pressure.

## TORQUE vs NET PRESSURE

■ MVW-06

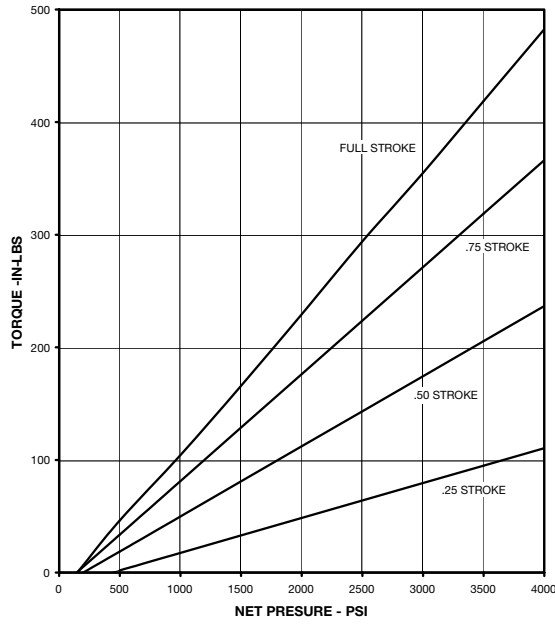

■ MVW-10

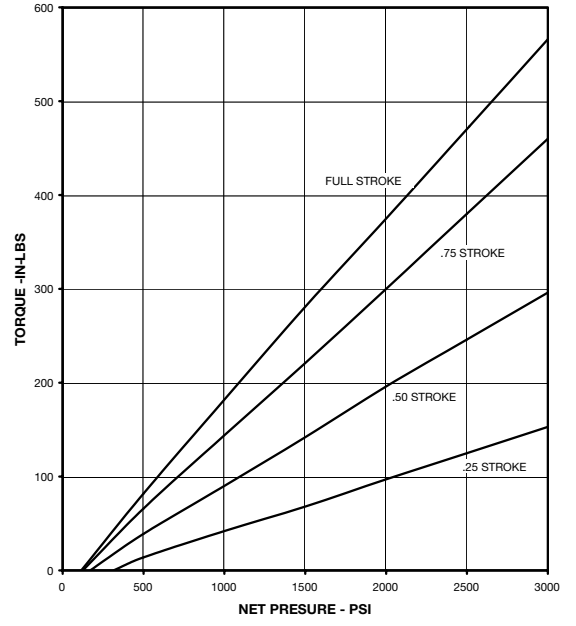

■ MVW-15

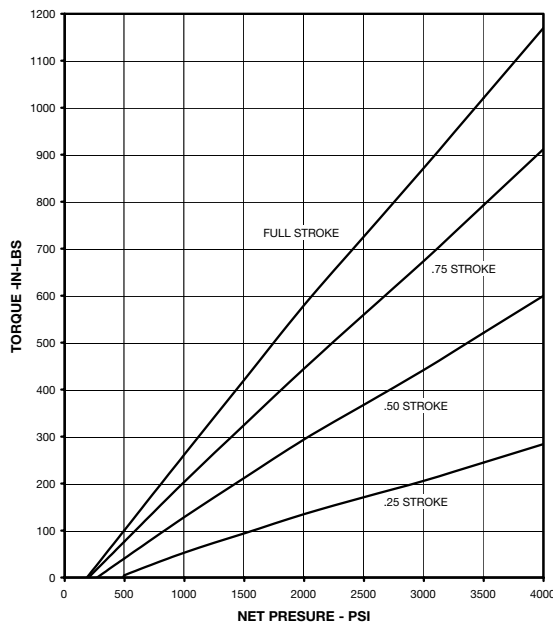

■ MVW-20

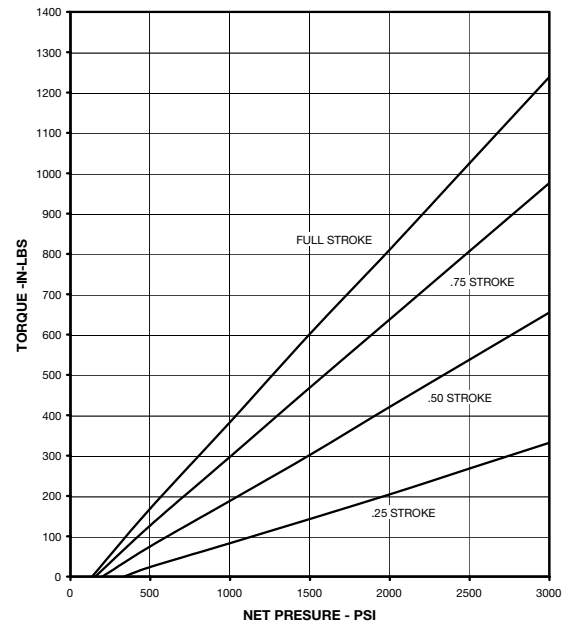

All curves are based on typical units operating with 140 SSU fluid at 125°F and 75 psi back pressure.

## HORSEPOWER vs SPEED

**MVW-06**  
(Full Stroke)

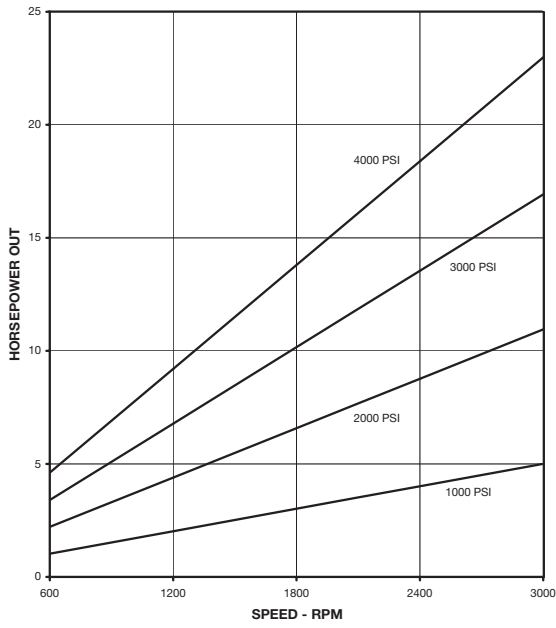

**MVW-10**  
(Full Stroke)

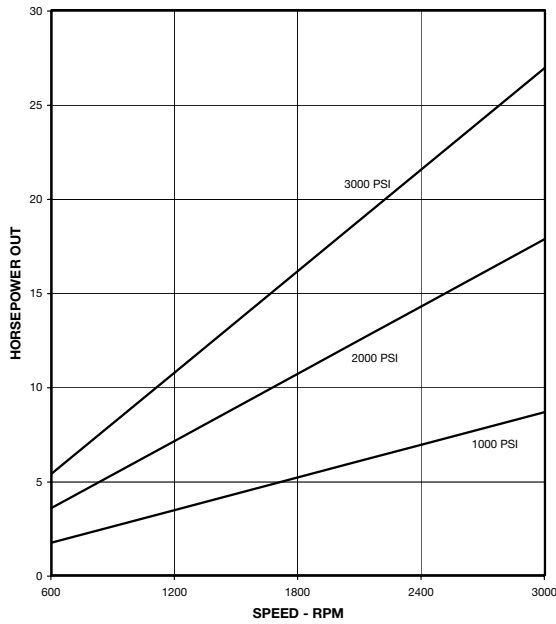

**MVW-15**  
(Full Stroke)

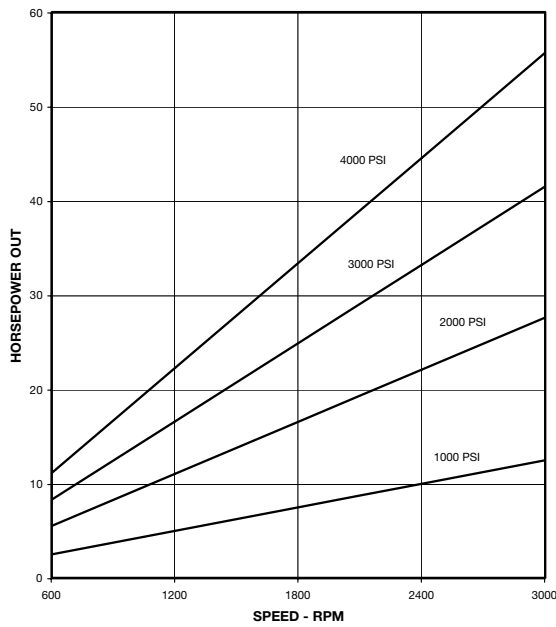

**MVW-20**  
(Full Stroke)

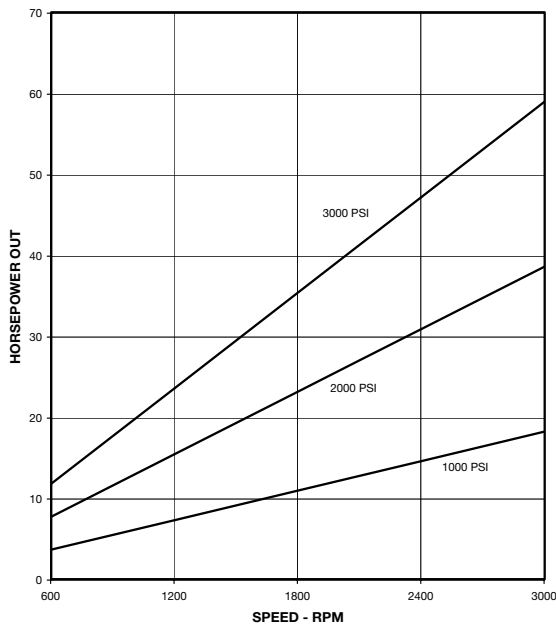

# Oilgear Performance Curves

# PERFORMANCE

All curves are based on typical units operating with 140 SSU fluid at 125°F and 75 psi back pressure.

## OVERALL EFFICIENCY vs NET PRESSURE

■ **MWV-06**  
(Full Stroke)

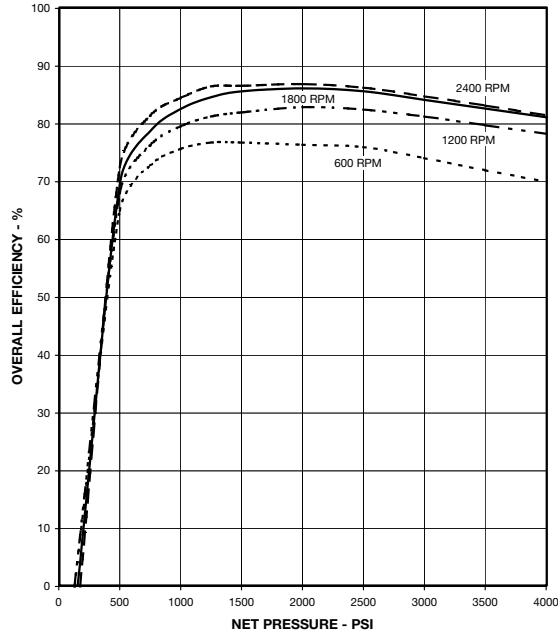

■ **MWV-10**  
(Full Stroke)

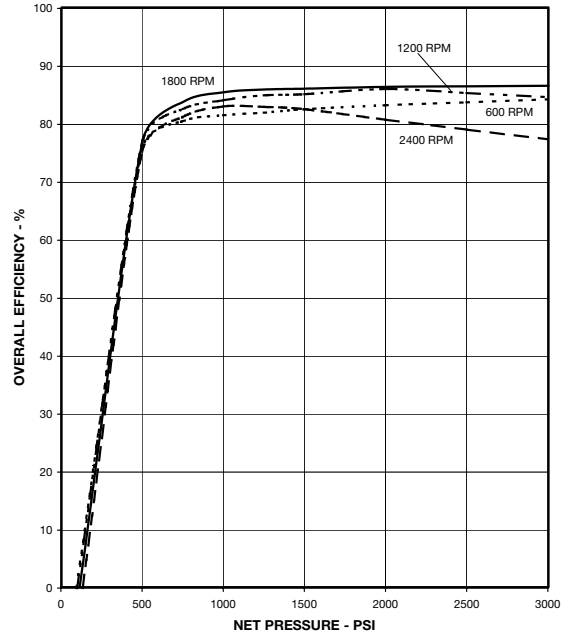

■ **MWV-06**  
(1800 RPM)

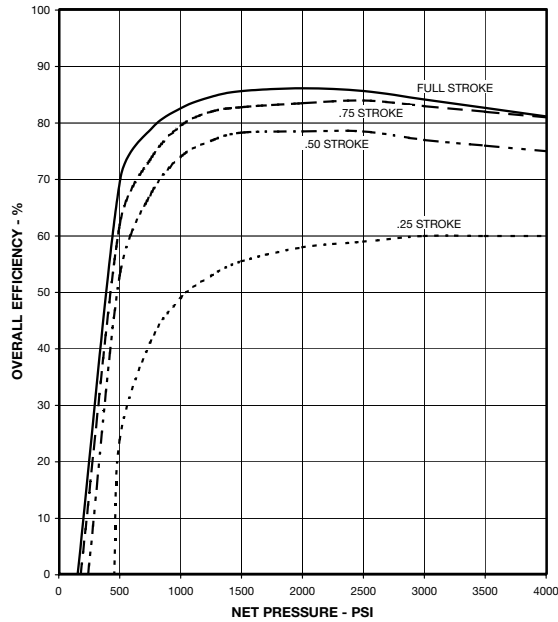

■ **MWV-10**  
(1800 RPM)

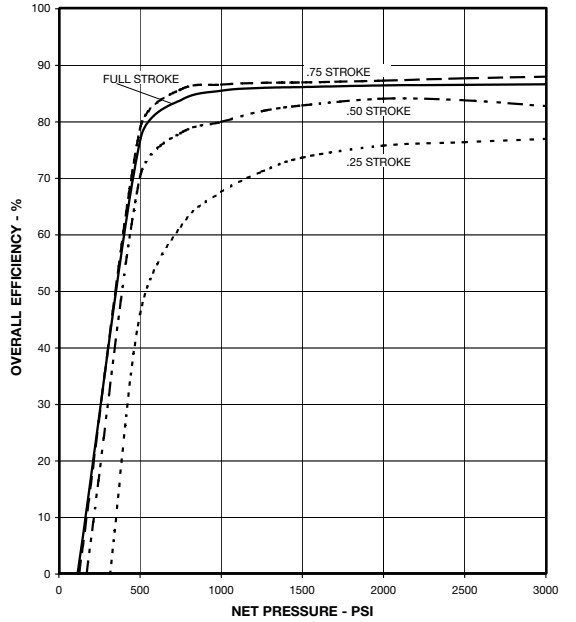

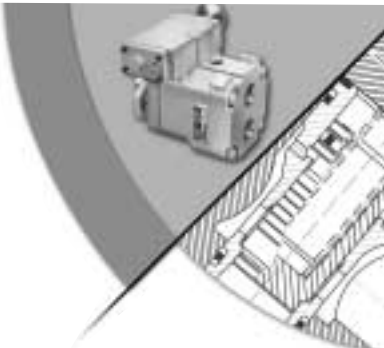

All curves are based on typical units operating with 140 SSU fluid at 125°F and 75 psi back pressure.

**MVW-15**  
(Full Stroke)

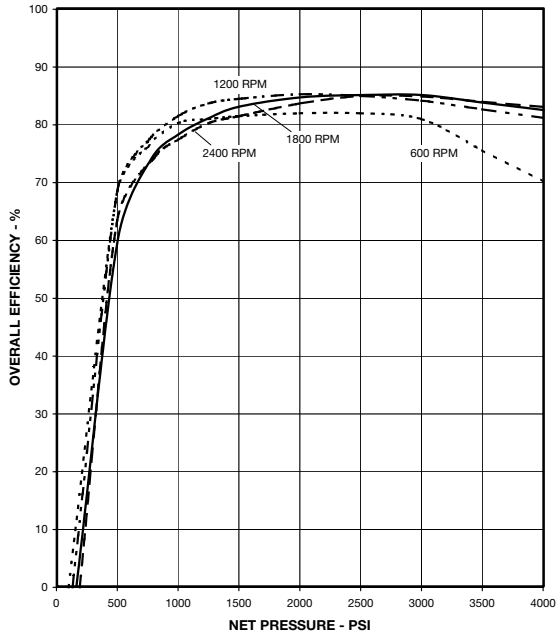

**MVW-20**  
(Full Stroke)

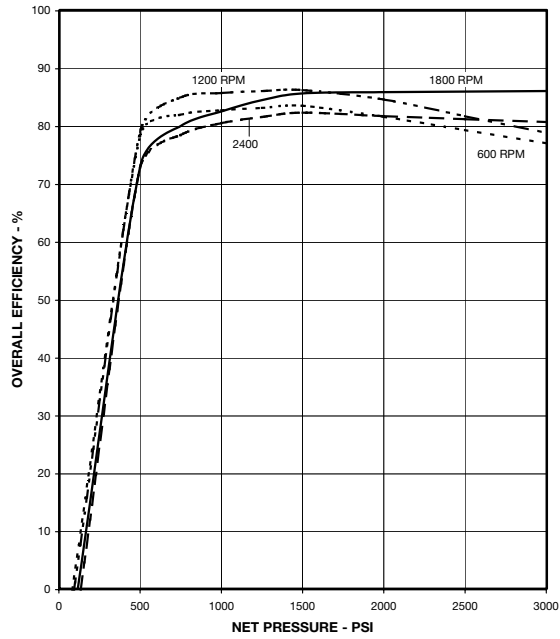

**MVW-15**  
(1800 RPM)

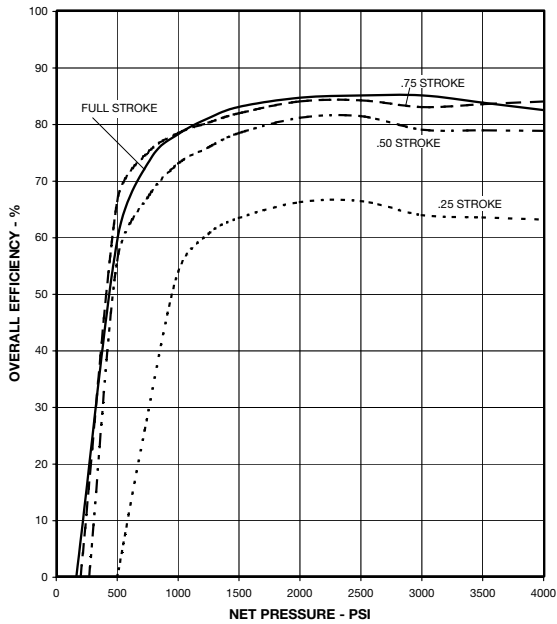

**MVW-20**  
(1800 RPM)

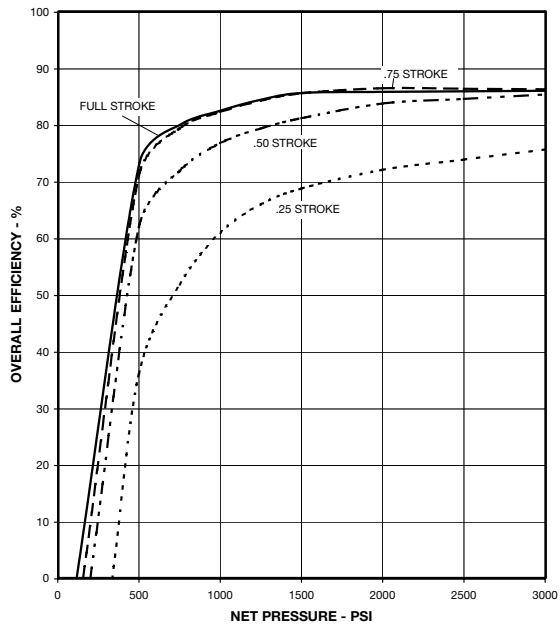

# Oilgear Performance Curves

## HOW TO ORDER

BLOCK NUMBER EXPLANATION	1	2	3	—	4	—	5	6	—	7	8
FIXED MOTOR EXAMPLE	M	F	W	—	15A	—	A	Y	—	NN	NN
VARIABLE MOTOR EXAMPLE	M	V	W	—	06A	—	A	S	—	HN	NN

- 1 = UNIT**  
M = Motor
- 2 = TYPE**  
F = Fixed Displacement  
V = Variable Displacement
- 3 = DESIGN SERIES**  
W = Hydrodynamic Bearing
- 4 = UNIT SIZE**  
W. Des.  
06A = 0.85 cipr  
10A = 1.36 cipr  
15A = 2.05 cipr  
20A = 2.82 cipr
- 5 = PORT TYPE**  
A = SAE Straight Thread
- 6 = SHAFT END**  
Y = Keyed SAE  
S = Splined SAE  
B = Keyed Belt Drive  
C = (c) Splined Belt Drive
- 7 = CONTROL TYPE**  
HD = Hydraulic two position  
HN = Handwheel  
MN = Pintle for Lever  
\*RU = Solenoid/Dual Position  
NN = Fixed Displacement (no control)
- \*115VAC/60Hz. standard, other voltages available (additional cost)
- 8 = DISPLACEMENT STOPS**  
NN = No Volume Stops  
SA = Minimum Stop (HD, MN, RU, HN)  
SN = Maximum Stop (HN, RU, MN)  
SB = Both Min. & Max. (HN, MN, RU)

NOTES



---

# Oilgear Notes

# Oilgear

**World Headquarters**  
**The Oilgear Company**

2300 South 51st Street Milwaukee, WI USA 53219  
phone: 414/327-1700 fax: 414/327-0532

[www.oilgear.com](http://www.oilgear.com)

For more information about your application or the products  
in this brochure, please contact your nearest Oilgear facility.



**AUSTRALIA**

Oilgear Towler Australia Pty. Ltd.

**BRAZIL**

Oilgeardo Brazil Hydraulica Ltd.

**CANADA**

The Oilgear Company

**FRANCE**

Oilgear Towler S.A.

**GERMANY**

Oilgear Towler GmbH

**INDIA**

Oilgear Towler Polyhydron Pvt. Ltd.  
Towler Automation Pvt. Ltd.

**ITALY**

Oilgear Towler S.r.l.

**JAPAN**

The Oilgear Japan Company

**KOREA**

Oilgear Towler Korea Co. Ltd.

**MEXICO**

Oilgear Mexicana S.A. de C.V.

**SPAIN**

Oilgear Towler S.A.

**TAIWAN**

Oilgear Towler Taiwan Co. Ltd.

**UNITED KINGDOM**

Oilgear Towler Ltd.

**UNITED STATES OF AMERICA**

The Oilgear Company

